

LAN Transformer

100/1000 BASE-T P20805G Equivalent to LH20210DF

REV: 0

A. MECHANICAL (unit:mm)

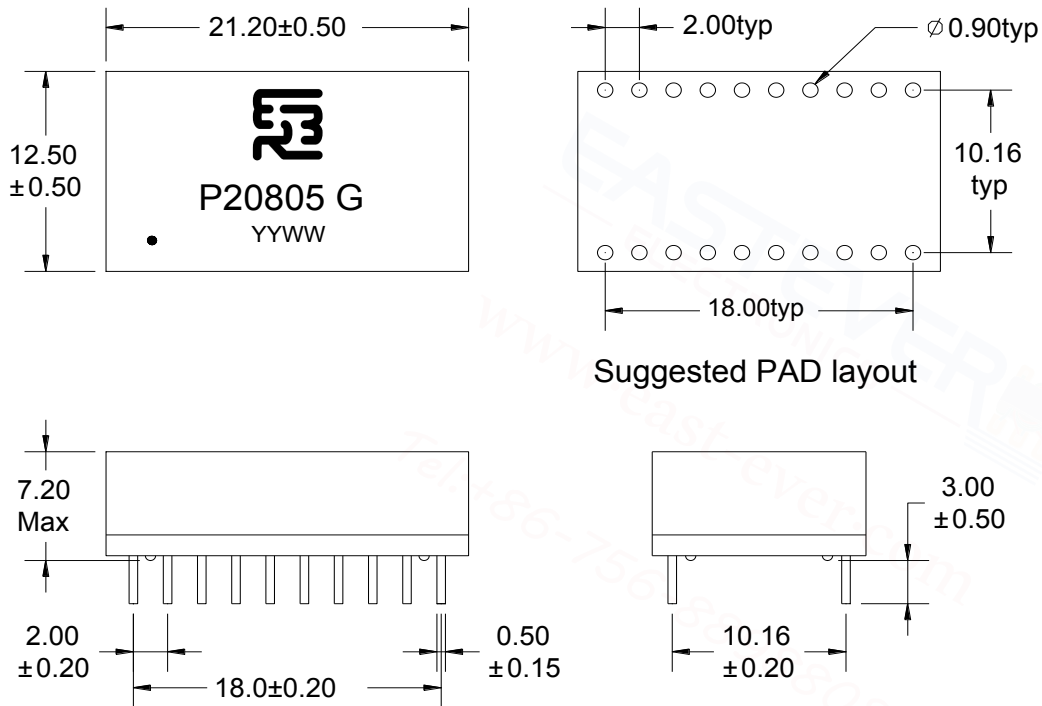

B. SCHEMATICS

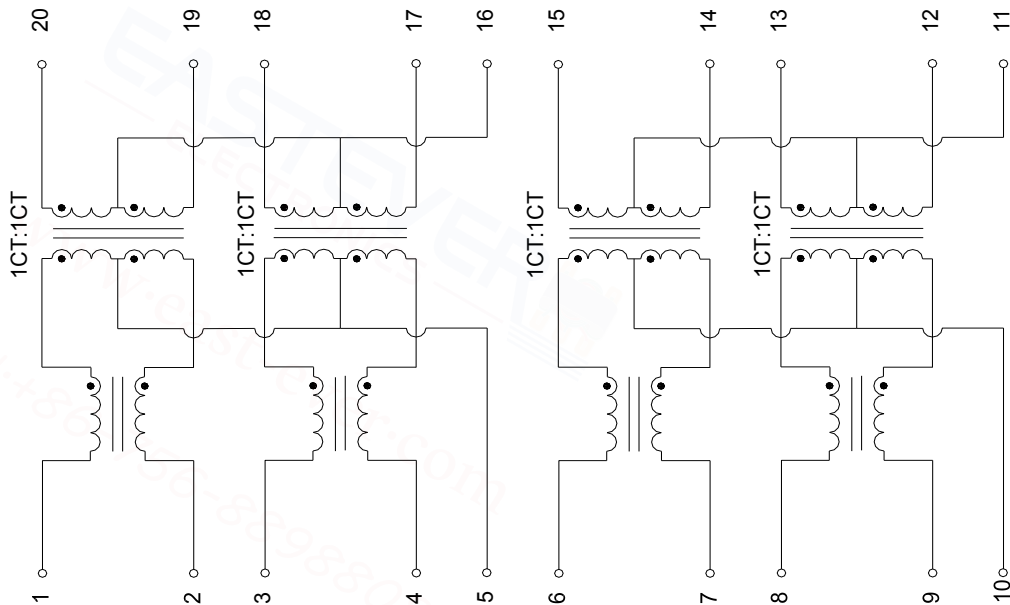

LAN Transformer

100/1000 BASE-T P20805 G

REV: 0

C. ELECTRICAL SPECIFICATIONS @25°C

1. OCL: 350uH Min @ 100 KHz, 0.1V with 8mA DC BIAS
2. Leakage Inductance: 0.5uH Max @ 100KHz, 0.1V
3. DCR: 1400mΩ Max
4. Turns Ratio: 1CT:1CT±5%
5. Insertion Loss: -1.1 dB Max @ 1-100 MHz
6. Return Loss: -18 dB Min @ 1-30 MHz
-14.4 dB Min @ 40 MHz
-13.1 dB Min @ 50 MHz
-12 dB Min @ 60-80 MHz
-10 dB Min @ 100 MHz
7. Cross Talk: -30 dB Min @ 1-100 MHz
8. Common Mode Rejection: -30 dB Min @ 1-100 MHz
9. Isolation Hipot: 1500VAC 1mA 60S
10. Operating temperature 0°C to +70°C
11. Storage temperature -20°C to +125°C

CI. PACKAGE INFORMATION

Package Quantity:

One Tube=24Pcs

One Carton=24*77=1848Pcs

One Export Carton=1848*4=7392Pcs

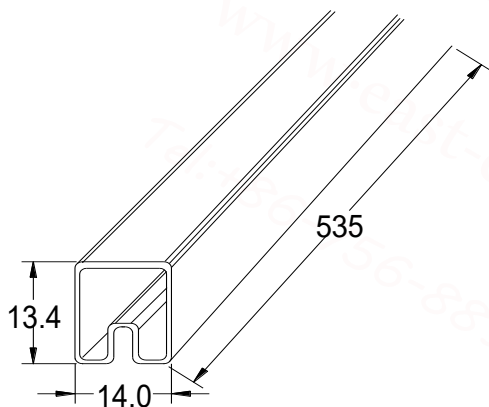

Tube:
535*13.4*14.0mm

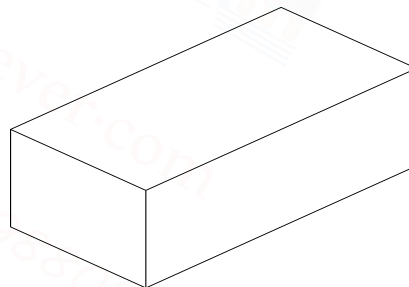

Inner Carton:
L575*W180*H100mm

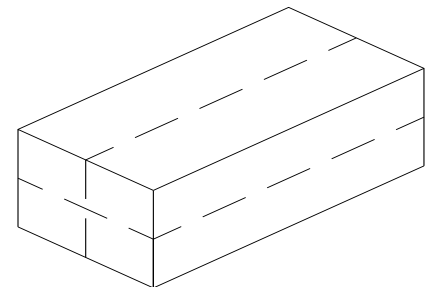

Export Carton:
L580*W380*H240mm