

RF Balun Transformer

ETB75011-055S-087

2022-08-15 Rev.3



75Ω 1:1 Transmission Line Transformer 50-2000 MHz

Outline Drawing(mm)

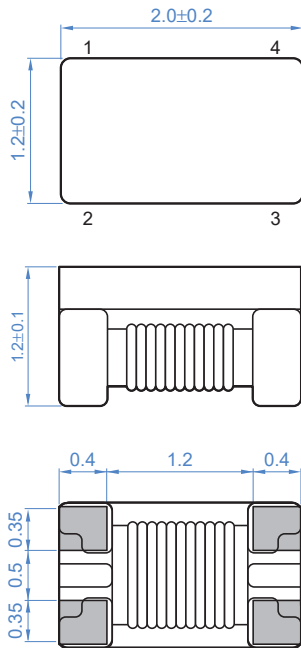

Circuit Diagram

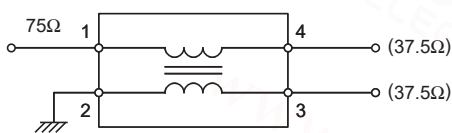

Recommended layout(mm)

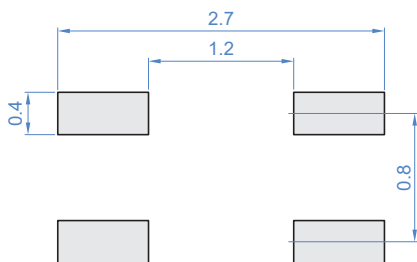

Features

- RF Power, 0.25W
- DC Current, 300 mA
- 260°C Reflow Compatible
- RoHS compliant and lead free
- Operating temperature range: -40°C to +85°C
- Storage temperature range: -55°C to +100°C

Applications

- For Dcscis 3.0 & 3.1 Cable Modem.
- For Wideband Push-pull Amplifiers.
- For CATV Amplifiers Module & Set top box.
- For CATV Optical Receivers and Amplifiers.
- For VHF/UHF Transmitters and Push-pull Amplifiers.

Electrical Specifications:TA=25°C, 0dBm, Z0=75Ω

Parameter	Test Conditions	Units	Min	Typ	Max
Main line Loss (Pin1-4)	50-1250MHz 1250-2000MHz	dB	—	0.7 1.8	1.2 2.2
Main line Loss (Pin1-3)	50-1250MHz 1250-2000MHz	dB	—	0.7 0.7	1.0 1.1
Amplitude Balance	50-1250MHz 1250-2000MHz	dB	—	0.5 1.2	1.0 1.5
Phase Balance	50-1250MHz 1250-2000MHz	dB	°	5.0 10.0	15.0 18.0
Input Return Loss(Pin1)	50-1250MHz 1250-2000MHz	dB	12.0 10.0	35.0 14.0	—
CMRR	50-1250MHz 1250-2000MHz	dB	16.0 10.0	32.0 20.0	—

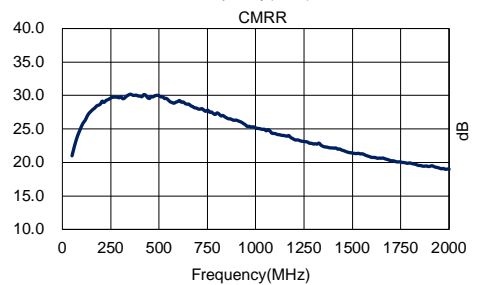
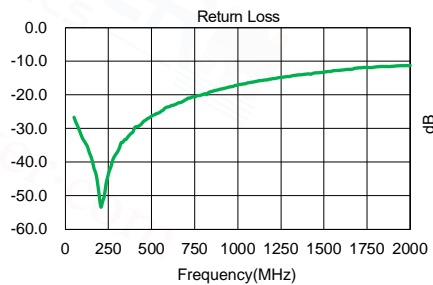
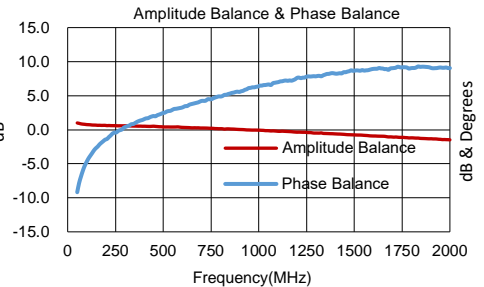
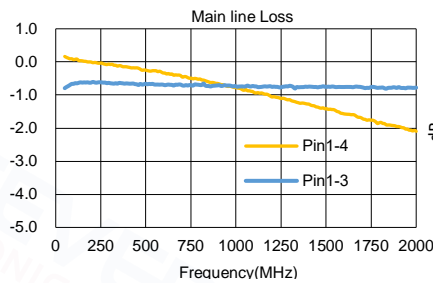

Carrier Tape Orientation

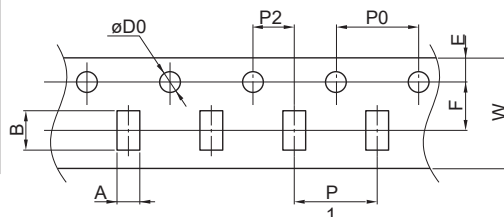

Tape & Reel Information

Parameter	Units	Value
Qty per reel	PCS	4000
Reel Size	mm	180
Tape Width	mm	8.00
P0	mm	4.00
A	mm	1.40
B	mm	2.30
K	mm	1.40

RF Balun Transformer

ETB75011-055S-087

2022-08-15 Rev.3



50Ω 1:1 Transmission Line Transformer 50-1000 MHz

Outline Drawing(mm)

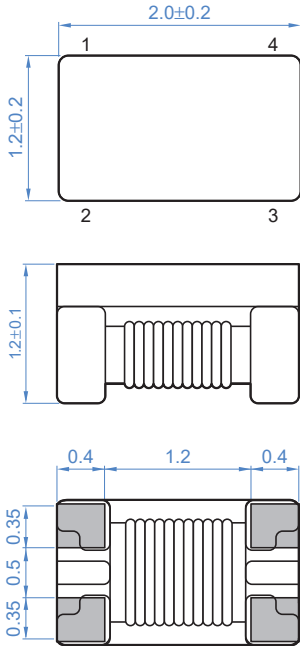

Circuit Diagram

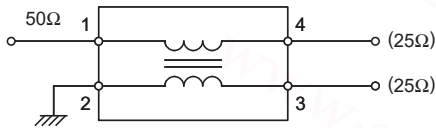

Recommended layout(mm)

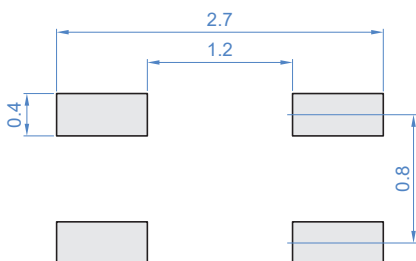

Features

- RF Power, 0.25W
- DC Current, 300 mA
- 260°C Reflow Compatible
- RoHS compliant and lead free
- Operating temperature range: -40 °C to +85 °C
- Storage temperature range: -55 °C to +100 °C

Applications

- IFor Motorola Walkie-talkie.
- For Car Streaming Media Rearview Mirror.
- For Broadband and Wireless Communications.
- For Wireless Microphone & Marine Communications.
- For Ideally Suited LTE, Cellular, UMTS, WiFi, WiMAX.
- For Differential Modulator/demodulator and Active Mixers.

Electrical Specifications:TA=25 °C, 0dBm, Z0=50Ω

Parameter	Test Conditions	Units	Min	Typ	Max
Main line Loss (Pin1-4)	40-1000MHz	dB	—	0.7	1.1
Main line Loss (Pin1-3)	40-1000MHz	dB	—	0.7	1.1
Amplitude Balance	40-1000MHz	dB	—	0.5	0.8
Phase Balance	40-1000MHz	°	—	5.0	10.0
Input Return Loss(Pin1)	40-1000MHz	dB	20.0	32.0	—

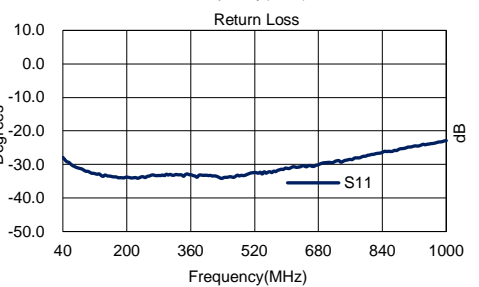
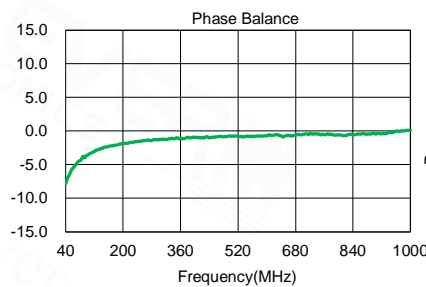
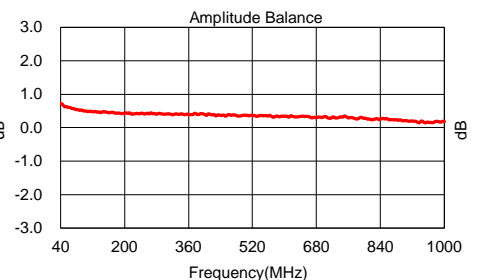
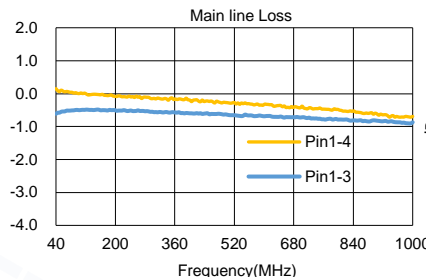

Carrier Tape Orientation

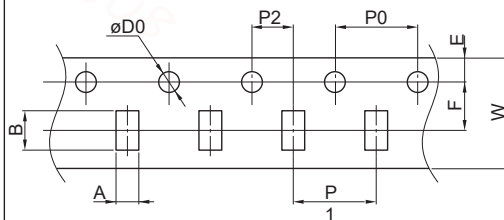

Tape & Reel Information

Parameter	Units	Value
Qty per reel	PCS	4000
Reel Size	mm	180
Tape Width	mm	8.00
P0	mm	4.00
A	mm	1.40
B	mm	2.30
K	mm	1.40