

# LAN Transformer

100/1000 BASE-T ES24719PTG

REV: 0

## A. MECHANICAL(unit:mm)

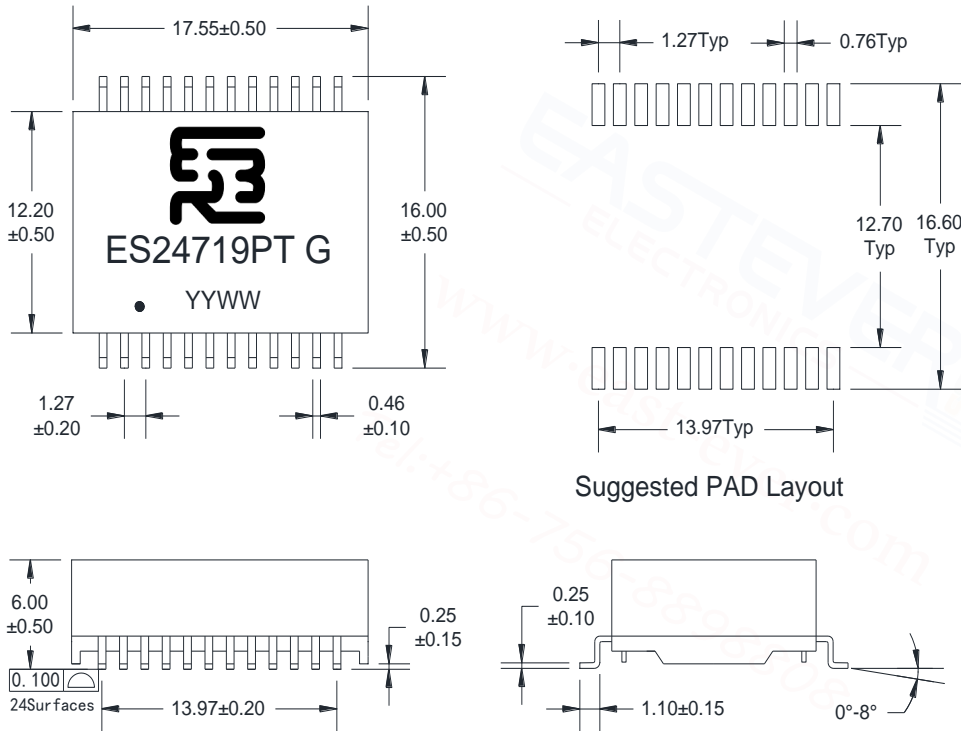

## B. SCHEMATICS

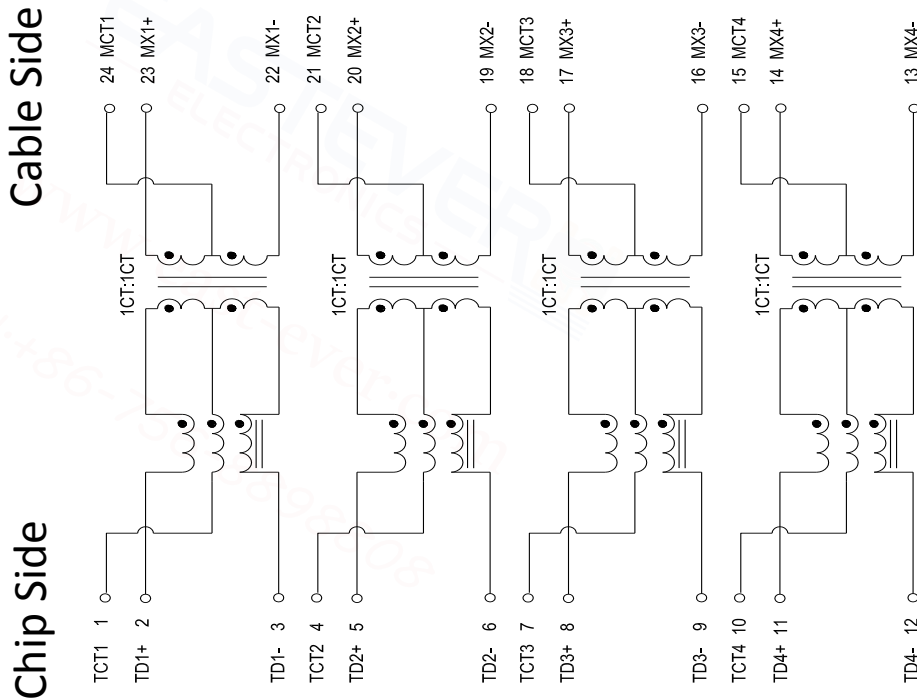

# LAN Transformer

100/1000 BASE-T ES24719PTG

REV: 0

## D. ELECTRICAL SPECIFICATIONS @25°C

1. OCL: 350uH Min @ 100KHz, 0.1V 8mA DC BIAS
2. Leakage Inductance: 0.5uH Max @ 100KHz, 0.1V
3. DCR : 1400mΩ Max
4. Turns Ratio: 1CT:1CT±5%
5. Insertion Loss: -1.20dB Max @ 0.5-1.0 MHz     $-0.2-0.002*f^{1.4}$  dB Max @ 1-125 MHz
6. Return Loss:    -16.0dB Min @ 1-40 MHz  
                           $-10+20*\log (f/80)$  dB Min @ 40.1-100 MHz
7. Cross Talk: -30 dB Min @ 1-100 MHz
8. Cmmon Mode Rejection: -30 dB Min @ 1-100 MHz
9. Isolation Hipot: 1500VAC 1mA 60S
10. Operating temperature -40°C to +85°C
11. Storage temperature -40°C to +125°C
12. IEEE802.3at compliant performance---720mA Current Capability

## E. PACKAGE INFORMATION

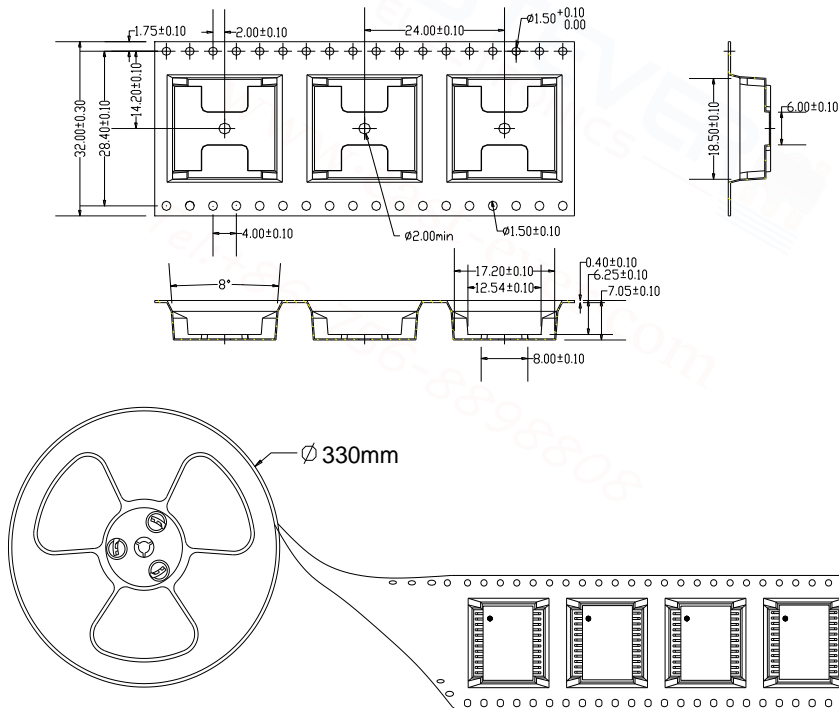

Package Quantity:

One Reel=350Pcs

One Inner Carton=350\*2=700Pcs

One Export Carton=700\*5=3500Pcs